

Rebling Datasheet: 250 amp LFT-style Lithium Battery Terminal

Our LFT-style terminal is the most economical, smallest footprint, simplest environmental seal, battery terminal which can reduce connector costs on a single microgrid energy storage system by \$2,000 and offers a battery module designer the protection options of snap-on rigid or flexible covers. The brass core of our LFT is available with nickel plating for harsh environments and stays cool even at extreme charge or discharge rates. Equipping your design with these watertight, single pole, wrench disconnect terminals will enable system integrators to easily incorporate your power modules into the MicroGrid, Reserve Power, Vehicle Electrification or APU systems the end-user requires, regardless of battery chemistry. Whether you are coupling battery modules in series for a stationary power application, an immersion-cooled motive power system, a single SLI module, a telecom or datacenter reserve power system or simply bringing DC power from the inside to the outside of a metal panel which is at least 0.110" (2.8 mm) thick, our LFT-style 250 amp Terminals, Covers and Accessories were designed with your application in mind.



Electrical

Current each current profile causes a max 30° C temperature rise when tested per IEC 61984

Current Profile #1	Continuous Rated Current (CRC)	-----	250 amps
Current Profile #2	50% CRC for 60min + 1 sec peak + 50% CRC for 60 min	-----	1,500 amps
Current Profile #3	50% CRC for 60min + 10 sec peak + 50% CRC for 60 min	-----	1,000 amps
Current Profile #4	50% CRC for 60min + 30 sec peak + 50% CRC for 60 min	-----	750 amps
Current Profile #5	50% CRC for 60min + 60 sec peak + 50% CRC for 60 min	-----	500 amps

Voltage & Resistance

Continuous Rated Voltage	UL1977 Section 17	2,000 volts
Minimum Dielectric Withstanding Voltage	UL1977 Section 17	5,000 volts
Insulation Resistance	MIL-PRF-18148D Section 3.12.6	500 mega-ohms
Maximum Contact Resistance	MIL-STD-202H Method 307	70 micro-ohms

Mechanical & Environmental

Flammability Rating:	Terminal and Rigid Covers	-----	UL 94	5VA
	Flexible Cover		UL 94	V-0
Environmental Sealing:	with Optional Gasket	-----	IEC 60529	IP68+ watertight
	without Optional Gasket		IEC 60529	IP65
Operating Temperature:	Terminal and Rigid Covers	-----		-40 to +125 C
	Flexible Cover			-40 to +90 C
Mechanical Shock		MIL-STD-202H Method 213 Condition A		50 Gs – 3 axes
Vibration		MIL-STD-202H Method 204 Condition A		10 Gs – 3 axes
Minimum Metal Panel Thickness Required for Mounting				0.110" (2.8 mm)
Maximum Wire Size:	Terminal only or with Flexible Cover	-----		4/0 (110 mm ²)
	with Rigid Short Snap-On Cover			3/0 (80 mm ²)
	with Rigid Long Snap-On Cover			2 AWG (35 mm ²)

Compliance & Conformance

RoHS, REACH, CMRT/3TG
 UL and CE Conformance

All parts listed on this datasheet are RoHS, REACH and CMRT/3TG Compliant
 Declarations of UL and CE Conformance can be downloaded from Rebling.com

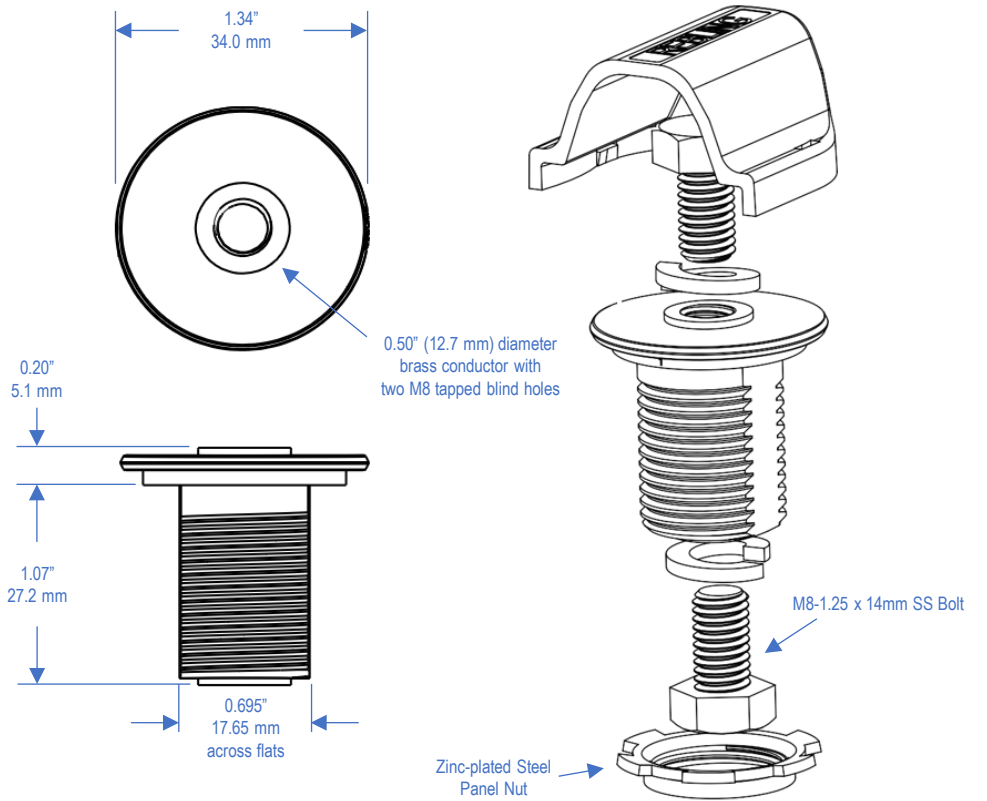

For complete dimensions, download 3D Step files of Terminal and Accessories at Rebling.com

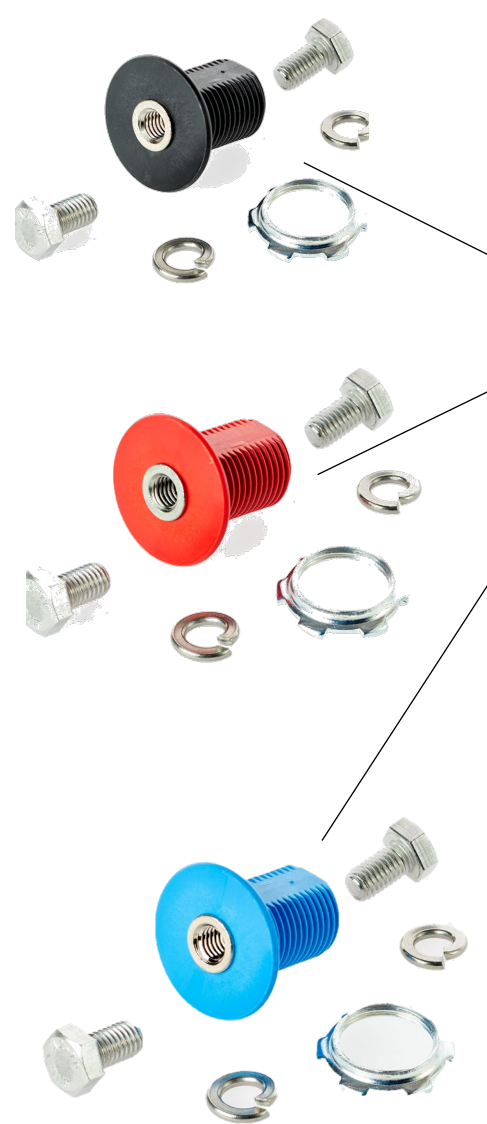

P/N	Description	Plastic Color	Weight (Grams)	Min Thick (mm)	UL 94 Rating	UL Material Yellow Card # **
LFT-P-B	Terminal Kit*, Brass, Nickel plated	Black	62	2.1	5VA	E121562-101513781
LFT-B-B	Terminal Kit*, Brass, Unplated	Black	62	2.1	5VA	E121562-101513781
LFT-P-R	Terminal Kit*, Brass, Nickel plated	Red	62	2.1	5VA	E121562-101513781
LFT-B-R	Terminal Kit*, Brass, Unplated	Red	62	2.1	5VA	E121562-101513781
LFT-P-E	Terminal Kit*, Brass, Nickel plated	Blue	62	2.1	5VA	E121562-101513781
LFT-B-E	Terminal Kit*, Brass, Unplated	Blue	62	2.1	5VA	E121562-101513781
<p>*Terminal Kit = one Terminal + one Panel Nut + two Bolts + two Split Washers, all parts in a small poly bag **UL Material Yellow Cards can be downloaded from ULprospector.com</p>						

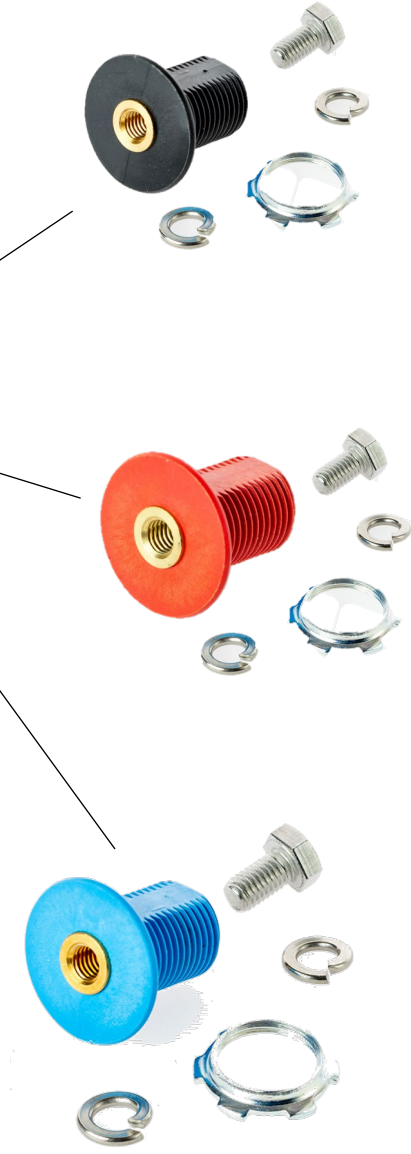

Rebling Datasheet: 250 amp LFT-style Lithium Battery Terminal

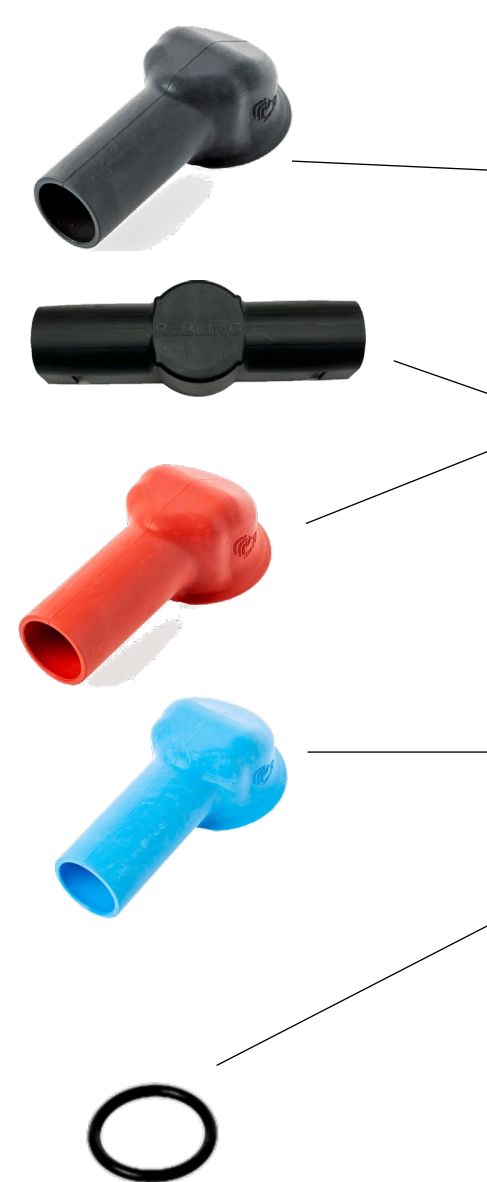

P/N	Description	Plastic Color	Weight (Grams)	Min Thick (mm)	UL 94 Rating	UL Material Yellow Card # **
713A1806-B	Flexible Snap-On Cover (3.75" OAL, 0.82" ID)	Black	26	2.0	V-0	E80017-250533
698A1789-S-B	Rigid Snap-On Cover, Short (1.44" OAL)	Black	9	2.0	5VA	E121562-101513781
698A1789-L-B	Rigid Snap-On Cover, Long (2.23" OAL)	Black	12	2.0	5VA	E121562-101513781
850A1991-B	Angled Cover for Two Cables, Black	Black	20	1.5	V-0	E121562-220886
850A1992-B	Straight Cover for Two Cables, Black	Black	20	1.5	V-0	E121562-220886
713A1806-R	Flexible Snap-On Cover (3.75" OAL, 0.82" ID)	Red	26	2.0	V-0	E80017-250533
698A1789-S-R	Rigid Snap-On Cover, Short (1.44" OAL)	Red	9	2.0	5VA	E121562-101513781
698A1789-L-R	Rigid Snap-On Cover, Long (2.23" OAL)	Red	12	2.0	5VA	E121562-101513781
850A1991-R	Angled Cover for Two Cables, Red	Red	20	1.5	V-0	E121562-220886
850A1992-R	Straight Cover for Two Cables, Red	Red	20	1.5	V-0	E121562-220886
713A1806-E	Flexible Snap-On Cover (3.75" OAL, 0.82" ID)	Blue	26	2.0	V-0	E80017-250533
698A1789-S-E	Rigid Snap-On Cover, Short (1.44" OAL)	Blue	9	2.0	5VA	E121562-101513781
698A1789-L-E	Rigid Snap-On Cover, Long (2.23" OAL)	Blue	12	2.0	5VA	E121562-101513781
700A1799	O-Ring for LFT Terminal	Black	0.5	2.5	V-0	Material = EPDM
*Terminal Kit = one Terminal + one Panel Nut + two Bolts + two Split Washers, all parts in a small poly bag **UL Material Yellow Cards can be downloaded from ULprospector.com						

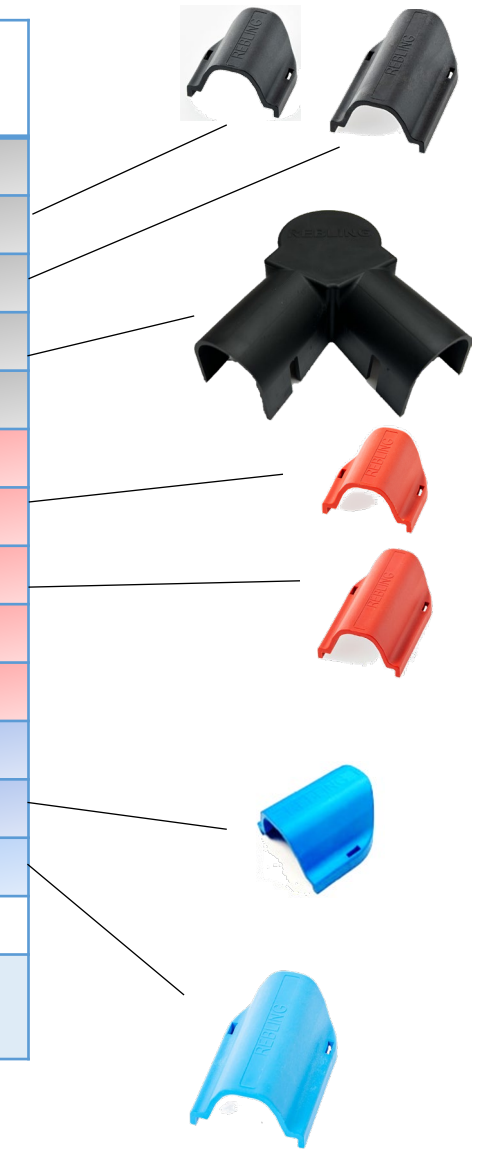

Rebling Datasheet: 250 amp LFT-style Lithium Battery Terminal

Mounting and Assembly

Minimum Panel Thickness (aluminum or steel) 0.110" (2.8 mm)

Mounting Hole Pattern (see diagram below) One Double-D Hole

Torque on M8 Bolts:

Recommended	50 to 60 in-lbs (5.6-6.8 Nm)	electrical performance does not get better or worse above 50 in-lbs (5.6 Nm)
Maximum Recommended	240 in-lbs (27 Nm)	a Grade 4, M8 stainless bolt will snap at 330 in-lbs (37 Nm)

Recommended Torque on Panel Nut

Without O-Ring	30-35 in-lbs (3.4-4.0 Nm)	1/6 turn after finger tight
With O-Ring	30-35 in-lbs (3.4-4.0 Nm)	4/6 turn after finger tight

Maximum Crimp Lug Tongue Width:

with Flexible Cover	1.10" (28 mm)
with Short Rigid Snap-on Cover	0.91" (23 mm)
with Long Rigid Snap-on Cover	0.70" (18 mm)

Application Notes

- Watertight is superior to IP68:** Rebling terminals are completely watertight to a depth of 20 meters which is superior to any IP Rating. The definitions of IP67, IP68 and IP69k per IEC 60529 state that "water may penetrate the seal but shall do no harm", a condition that is unacceptable to lithium battery designers.
- Cable Pulling Lubricant:** when using 4/0 (110 mm²) cable with the flexible cover, crimp the lug to the cable then push the lug into the cover using lubricant
- Panel Nut Wrench:** Gardner Bender wrench # LNW-500 is recommended for tightening the panel nut
- Customized Socket Wrench:** if space prohibits use of the LNW-500 wrench, a 1 1/16 inch, 12 point socket can be modified by grinding off the socket's lead-in bevel, enabling it to engage the teeth on the panel nut which enables tightening the panel nut with a socket wrench.
- Loctite (Thread Locking Fluid) Warning:** some thread-locking fluids can cause a terminal's plastic body to crack. Loctite's datasheets warn that its products should not be used near any thermoplastic because their fluid (or its vapor) can change the chemical structure of thermoplastic, causing stress cracks to appear weeks or months after the fluid was applied to metal bolts on or near a terminal.

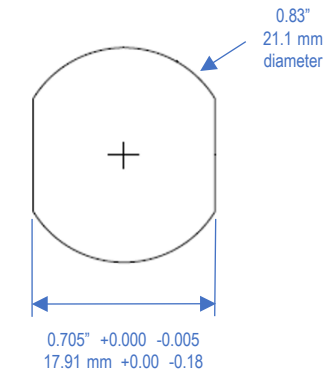

Mounting Hole Pattern